

DINION IP starlight 6000 HD

www.boschsecurity.com



BOSCH
Invented for life



- ▶ Excellent low-light performance
- ▶ Built-in Essential Video Analytics to trigger relevant alerts and quickly retrieve data
- ▶ Intelligent Streaming and Intelligent Dynamic Noise Reduction for low network strains and storage costs
- ▶ Extended Dynamic Range mode to see details in bright and dark areas simultaneously
- ▶ Auto back focus for fast installation

This camera provides clear images 24/7 – even at night or under low-light conditions.

The exceptional starlight sensitivity enables this camera to work with a minimum of ambient light. The extended dynamic mode provides detailed images in scenes with challenging lighting.

The camera is available in 1080p or 720p resolution versions and provides up to 60 images per second. There is a selection of high quality lenses separately available.

Functions

Exceptional low-light performance

The latest sensor technology combined with the sophisticated noise suppression results in an exceptional sensitivity in color. The low-light performance is so good that the camera continues to provide excellent color performance even with a minimum of ambient light.

Fast performance

The 60 frames per second mode provides for optimum performance in fast action scenes that ensures no critical data is lost.

High Dynamic Range

The camera has High Dynamic Range. This is based on a multiple-exposure process that captures more details in the highlights and in the shadows even in the same scene. The result is that you can easily distinguish objects and features, for example, faces with bright backlight.

The actual dynamic range of the camera is measured using Opto-Electronic Conversion Function (OECF) analysis according to IEC 62676 Part 5. This method is used to provide a standard result which can be used to compare different cameras.

Essential Video Analytics

The built-in video analysis reinforces the Intelligence-at-the-Edge concept and now delivers even more powerful features. Essential Video Analytics is ideal for use in controlled environments with limited detection ranges.

The system reliably detects, tracks, and analyzes objects, and alerts you when predefined alarms are triggered. A smart set of alarm rules makes complex tasks easy and reduces false alarms to a minimum. Metadata is attached to your video to add sense and structure. This enables you to quickly retrieve the relevant images from hours of stored video. Metadata

can also be used to deliver irrefutable forensic evidence or to optimize business processes based on people counting or crowd density information. Calibration is quick and easy – just enter the height of the camera. The internal gyro/accelerometer sensor provides the rest of the information to precisely calibrate the video analytics.

Intelligent Auto Exposure

Fluctuations in backlight and front light can ruin your images. To achieve the perfect picture in every situation, Intelligent Auto Exposure automatically adjusts the exposure of the camera. It offers superb front light compensation and incredible backlight compensation by automatically adapting to changing light conditions.

Intelligent Dynamic Noise Reduction

Quiet scenes with little or no movement require a lower bitrate. By intelligently distinguishing between noise and relevant information, Intelligent Dynamic Noise Reduction reduces bitrate by up to 50%. Because noise is reduced at the source during image capture, the lower bitrate does not compromise on video quality.

Intelligent Dynamic Noise Reduction adjusts spatial and temporal filtering (3DNR) based on intelligent analysis of the scene content. Motion compensated temporal filtering (MCTF) reduces motion blur normally associated with standard temporal filtering. This maintains image quality of fast moving objects while still optimizing bitrate.

With Intelligent Dynamic Noise Reduction, our focus is to significantly reduce storage costs, and lessen network strain by only using bandwidth when needed.

Area-based encoding

Area-based encoding is another feature which reduces bandwidth. Compression parameters for up to eight user-definable regions can be set. This allows uninteresting regions to be highly compressed, leaving more bandwidth for important parts of the scene.

Bitrate optimized profile

The average typical optimized bandwidth in kbits/s for various image rates is shown in the table.

IPS	1080p	720p	480p
60	1900	1400	722
30	1600	1200	600
15	1274	955	478
12	1169	877	438
5	757	568	284
2	326	245	122

Scene modes

The camera has a very intuitive user interface that allows fast and easy configuration. Nine configurable modes are provided with the best settings for a variety of applications. Different scene modes can be selected for day or night situations.

Multiple streams

The innovative multi-streaming feature delivers various H.264 streams together with an M-JPEG stream. These streams facilitate bandwidth-efficient viewing and recording as well as integration with third-party video management systems.

The camera can run multiple independent streams that allows to set a different resolution and frame rate on the first and second stream. The user can also choose to use a copy of the first stream.

The third stream uses the I-frames of the first stream for recording; the fourth stream shows a JPEG image at a maximum of 10 Mbit/s.

Regions of interest and E-PTZ

Regions of Interest (ROI) can be user defined. The remote E-PTZ (Electronic Pan, Tilt and Zoom) controls allow you to select specific areas of the parent image. These regions produce separate streams for remote viewing and recording. These streams, together with the main stream, allow the operator to separately monitor the most interesting part of a scene while still retaining situational awareness.

Intelligent Tracking can follow objects within the defined regions of interest. Intelligent Tracking can autonomously detect and track moving objects or the user can click on an object which the tracker will then follow.

Easy installation

Power for the camera can be supplied via a Power-over-Ethernet compliant network cable connection. With this configuration, only a single cable connection is required to view, power, and control the camera. Using PoE makes installation easier and more cost-effective, as cameras do not require a local power source.

The camera can also be supplied with power from +12 VDC power supplies.

To increase system reliability, the camera can be simultaneously connected to both PoE and +12 VDC supplies. If one power source fails, the other source takes over without a reboot so providing power redundancy.

The auto-focus lens wizard makes it easy for an installer to accurately focus the camera for both day and night operation. The wizard is activated from the web browser or from the on-board camera push button making it easy to choose the workflow that suits best. The automatic motorized back focus adjustment with 1:1 pixel mapping ensures the camera is always focused accurately.

Automatic image rotation

The integrated gyro/accelerometer sensor automatically corrects the image orientation in steps of 90° if the camera is mounted at right angles or upside down. The sensor image can also be rotated manually through steps of 90°.

To efficiently capture details in long hallways without loss of resolution, mount the camera at right angles. The image is displayed upright at full resolution on your monitor.

Hybrid operation

A surge-protected analog video output allows full hybrid operation. This means that high resolution IP video streaming and an analog video output are available simultaneously. The hybrid functionality offers an easy migration path from legacy CCTV to a modern IP-based system.

Storage management

Recording management can be controlled by the Bosch Video Recording Manager (Video Recording Manager) or the camera can use iSCSI targets directly without any recording software.

Edge recording

Insert a memory card into the card slot to store up to 2 TB of local alarm recording. Pre-alarm recording in RAM reduces recording bandwidth on the network, and extends the effective life of the memory card.

Cloud-based services

The camera supports time-based or alarm-based JPEG posting to four different accounts. These accounts can address FTP servers or cloud-based storage facilities (for example, Dropbox). Video clips or JPEG images can also be exported to these accounts.

Alarms can be set up to trigger an e-mail or SMS notification so you are always aware of abnormal events.

True day/night switching

The camera is a true day/night camera with a mechanical filter for vivid daytime color and exceptional night-time imaging while maintaining sharp focus under all lighting conditions. The filter can be switched remotely, or automatically via a light level sensor or contact input.

Data security

Special measures are necessary to ensure the highest level of security for device access and data transport. On initial setup, the camera is only accessible over secure channels. You must set a service-level password in order to access camera functions. Web browser and viewing client access can be protected using HTTPS or other secure protocols that support state-of-the-art TLS 1.2 protocol with updated cipher suites including AES encryption with 256 bit keys. No software can be installed in the camera, and only authenticated firmware can be uploaded. A three-level password protection with security recommendations allows users to customize device

access. Network and device access can be protected using 802.1x network authentication with EAP/TLS protocol. Superior protection from malicious attacks is guaranteed by the Embedded Login Firewall, on-board Trusted Platform Module (TPM) and Public Key Infrastructure (PKI) support.

The advanced certificate handling offers:

- Self-signed unique certificates automatically created when required
- Client and server certificates for authentication
- Client certificates for proof of authenticity
- Certificates with encrypted private keys

Complete viewing software

There are many ways to access the camera's features: using a web browser, with the Bosch Video Management System, with the free-of-charge Bosch Video Client or Video Security Client, with the video security mobile app, or via third-party software.

Video security app

The Bosch video security mobile app has been developed to enable Anywhere access to HD surveillance images allowing you to view live images from any location. The app is designed to give you complete control of all your cameras, from panning and tilting to zoom and focus functions. It's like taking your control room with you.

This app, together with the separately available Bosch transcoder, will allow you to fully utilize our dynamic transcoding features so you can play back images even over low-bandwidth connections.

System integration and ONVIF conformance

The camera conforms to the ONVIF Profile S, ONVIF Profile G, and ONVIF Profile T specifications.

Third-party integrators can easily access the internal feature set of the device for integration into large projects. Visit the Bosch Integration Partner Program (IPP) website (ipp.boschsecurity.com) for more information.

Certifications and approvals

Standards	Type
Emission	EN 55032:2012 /AC2013 class B EN 50121-4:2016 FCC: 47CFR15, class B (2015-10-1)
Immunity	EN 50130-4:2011 /A12014 (PoE, +12VDC)* EN 50121-4:2016
Environmental	EN 50130-5:2011 Class II
Safety	EN 62368-1:2014/AC:2015 EN 60950-1:2006 /A11:2009 /A1:2010 / A12:2011 /A2:2013 UL 62368-1, Ed. 2, Dec 1st, 2014 UL 60950-1, Ed. 2, October 14, 2014 CAN/CSA-C22.2 No. 62368-1 CAN/CSA-C22.2 No. 60950-1

Standards	Type
HD	SMPTE 296M-2001 (Resolution: 1280x720) SMPTE 274M-2008 (Resolution: 1920x1080)
Color representation	ITU-R BT.709-6
ONVIF conformance	EN 50132-5-2:2011/AC:2012 EN 62676-2-3:2014
Image quality	UL 2802

* Chapters 7 and 8 (mains voltage supply requirement) are not applicable to the camera. However, if the system in which this camera is used needs to comply with this standard, then any power supplies used must comply with this standard.

Marks	CE, cULus, WEEE, RCM, EAC, CMIM, and China RoHS
-------	---

Region	Regulatory compliance/quality marks	
Europe	CE	
	CE	BT-SC 2018-E-021 EU Declaration of Conformity NBN-6_73023-Bx
USA	UL	ST-VS 2016-E-045

Installation/configuration notes

Controls

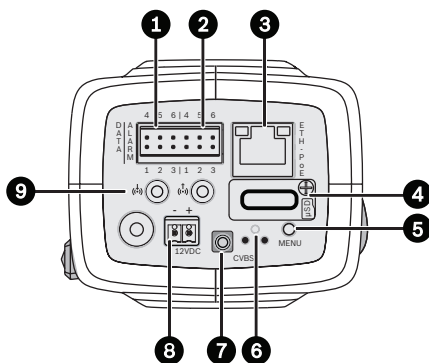

1	Data (RS485/422/232)	6	Reset button
2	Alarm in, alarm out	7	Video out (SMB connector)
3	10/100 Base-T Fast Ethernet	8	Power supply input
4	MicroSD card slot	9	Audio in / Audio out
5	Menu button		

Dimensions

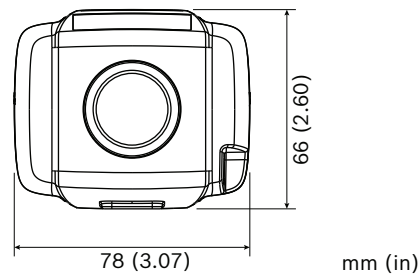
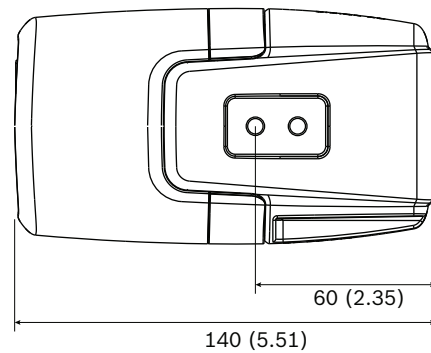

mm (in)

Technical specifications

Power (12 VDC/PoE version)

Input voltage Power-over-Ethernet (48 VDC nominal) and/or +12 VDC ±10% (auxiliary)

PoE IEEE 802.3af / 802.3at Type 1, Class 3

Power Consumption 7.2 W max.

Current consumption 600 mA max. (12 VDC)
200 mA max. (PoE 48 VDC)

Power (24 VAC/PoE version)

Input voltage Power-over-Ethernet (48 VDC nominal) and/or 24 VAC ±10% / +12 VDC ±10% (auxiliary)

PoE 802.3af (802.3at Type 1)
Power level: Class 3

Power Consumption 7.2 W max.

Current consumption 600 mA max. (12 VDC)
350 mA max. (24 VAC)
200 mA max. (PoE 48 VDC)

Sensor (1080p version)

Sensor type 1/2.8-inch CMOS

Effective pixels 1920 (H) x 1080 (V); 2MP (approx.)

Sensor (720p version)

Sensor type	1/2.8-inch CMOS
Effective pixels	1280 (H) x 720 (V)

Starlight sensitivity

(3100K, reflectivity 89%, 1/25, F1.2, 30IRE)

Color	0.0069 lx
Mono	0.0008 lx

Dynamic range – HDR mode

High Dynamic Range (10-bit, 3x exposure)	120 dB WDR
Measured according to IEC 62676 Part 5	110 dB WDR

Video streaming

Video compression	H.264 (MP); M- JPEG
Streaming	Multiple configurable streams in H.264 and M-JPEG, configurable frame rate and bandwidth. Regions of Interest (ROI)
Camera processing latency	<67 ms (max. average at 1080p60)
GOP structure	IP, IBP, IBBP
Encoding interval	1 to 50 [60] ips
Encoder regions	Up to eight areas with encoder quality settings per area

Video resolution (H x V)

1080p HD	1920 x 1080 (1080p version only)
Upright mode 1080p	1080 x 1920 (1080p version only)
1.3 MP (5:4)	1280 x 1024 (1080p version only)
720p HD	1280 x 720
Upright mode 720p	720 x 1280
D1 4:3 (cropped)	704 x 480
432p SD	768 x 432
288p SD	512 x 288

Camera installation

Application variant	Starlight mode (default) / HDR - extended dynamic mode
Base frame rate	25/30/50/60 fps (PAL/NTSC for analog output)
Mirror image	On / Off

Camera installation

Flip image	On / Off
Rotate	0° / 90° / 180° / 270°
Camera LED	Enable/disable
Analog output	Off, 4:3 letterbox, 4:3 crop, 16:9
Positioning	Coordinates / Mounting height
Lens wizard	Motorized back-focus

Video functions - color

Adjustable picture settings	Contrast, Saturation, Brightness
White Balance	2500 to 10000K, 4 automatic modes (Basic, Standard, Sodium lamp, Dominant color), Manual mode and Hold mode

Video functions - ALC

ALC level	Adjustable
Saturation	Adjustable from peak to average
Shutter	Automatic Electronic Shutter (AES); Fixed shutter (1/25[30] to 1/15000) selectable; Default shutter
Day/Night	Auto (adjustable switch points), Color, Monochrome

Video functions - enhance

Sharpness	Sharpness enhancement level selectable
Backlight compensation	On/off/Intelligent Auto Exposure (BLC)
Contrast enhancement	On/off
Signal-to-noise ratio (SNR)	>55 dB
Noise reduction	Intelligent Dynamic Noise Reduction Intelligent Streaming
Intelligent defog	Intelligent Defog automatically adjusts parameters for best picture in foggy or misty scenes (switchable)

Video content analysis

Analysis type	Essential Video Analytics
Features	Rule based alarms and tracking Line crossing Enter /leave field Follow route Loitering Idle / removed object People counting Crowd density estimation 3D tracking Audio detection (if microphone used)
Calibration / Geolocation	Automatic based on gyro / accelerometer data and camera height
Tamper detection	Maskable

Additional functions

Scene modes	10 pre-defined modes, including License Plate Recognition (LPR), with scheduler
Privacy Masking	Eight independent areas, fully programmable
Video authentication	Off / Watermark / MD5 / SHA-1 / SHA-256
Display stamping	Name; Logo; Time; Alarm message
Pixel counter	Selectable area
Camera rotation	Automatic detection with manual override (90°)

Local storage

Internal RAM	5 s pre-alarm recording
Memory card slot	Supports up to 32 GB microSDHC / 2 TB microSDXC card. Extreme lifetime and health monitoring support that provides early service indication. Recommended: Industrial microSD cards with health monitoring
Recording	Continuous recording, ring recording. Alarm/events/schedule recording

Input/output

Analog video out	CVBS (PAL/NTSC), 1 Vpp, SMB, 75 Ohm (surge protected)
Audio connectors	3.5 mm stereo jack (x2)
Audio line in	12 kOhm typical, 1 Vrms max
Audio line out	1 Vrms at 1.5 kOhm typical,
Alarm input	2 inputs
Alarm input activation voltage	+5 VDC to +40 VDC (+3.3 VDC with DC-coupled 22 kOhm pull-up resistor)

Input/output

Alarm output	1 output
Alarm output voltage	30 VAC or +40 VDC Maximum 0.5 A continuous, 10VA
Ethernet	RJ45
Data port	RS-232/422/485

Audio streaming

Standard	G.711, 8 kHz sampling rate L16, 16 kHz sampling rate AAC-LC, 48 kbps at 16 kHz sampling rate AAC-LC, 80 kbps at 16 kHz sampling rate
Signal-to-Noise Ratio	>50 dB
Audio Streaming	Full-duplex / half duplex

Network

Protocols	IPv4, IPv6, UDP, TCP, HTTP, HTTPS, RTP/RTCP, IGMP V2/V3, ICMP, ICMPv6, RTSP, FTP, ARP, DHCP, APIPA (Auto-IP, link local address), NTP (SNTP), SNMP (V1, V3, MIB-II), 802.1x, DNS, DNSv6, DDNS (DynDNS.org, selfHOST.de, no-ip.com), SMTP, iSCSI, UPnP (SSDP), DiffServ (QoS), LLDP, SOAP, Dropbox™, CHAP, digest authentication
Encryption	Full end-to-end encryption with supported VMS Network: TLS1.0/1.2, AES128, AES256 Local storage: XTS-AES
Ethernet	10/100 Base-T, auto-sensing, half/full duplex
Connectivity	Auto-MDIX
Interoperability	ONVIF Profile S, ONVIF Profile G, ONVIF Profile T GB/T 28181

Optical

Lens mount	CS mount (C-mount with adapter ring)
Lens connector	Standard 4-pin DC-iris connector
Lens Types	Manual and DC-Iris auto-detect with override DC-iris drive: max. 50 mA continuous
Lens Controls	Wizard from web page or camera button

Environmental

Operating Temperature	-20°C to +55°C (-4°F to 131°F)
Storage Temperature	-30°C to +70°C (-22°F to +158°F)
Operating Humidity	5% to 93% RH non condensing 5% to 100% RH condensing
Storage Humidity	up to 98% RH

Mechanical

Dimensions (W × H × L)	78 × 66 × 140 mm (3.07 × 2.6 × 5.52 inch) without lens
Weight	690 g (1.52 lb) without lens
Color	RAL 9007 Metallic Titanium
Tripod Mount	Bottom (isolated) and top 1/4-inch 20 UNC
Sustainability	PVC free

Ordering information**NBN-63013-B Fixed camera 1MP HDR**

High-performance IP box camera for intelligent HD surveillance in low light and with hybrid IP/analog operation.

720p

Order number **NBN-63013-B**

EWE-D6HDIP-IW 12mths wrty ext DINION 6000 HD IP

12 months warranty extension

Order number **EWE-D6HDIP-IW**

NBN-63023-B Fixed camera 2MP HDR

High-performance IP box camera for intelligent HD surveillance in low light and with hybrid IP/analog operation.

1080p

Order number **NBN-63023-B**

EWE-D6HDIP-IW 12mths wrty ext DINION 6000 HD IP

12 months warranty extension

Order number **EWE-D6HDIP-IW**

NBN-65023-B Fixed camera 2MP HDR 24V

1080p

High-performance IP box camera for intelligent HD surveillance in low light and with hybrid IP/analog operation.

Order number **NBN-65023-B**

EWE-D6HDIP-IW 12mths wrty ext DINION 6000 HD IP

12 months warranty extension

Order number **EWE-D6HDIP-IW**

Accessories**LVF-5003C-P2713 Varifocal lens, 2.7-13mm, 3MP, CS mount**

Varifocal P-iris megapixel IR corrected lens with 1/2.7 inch sensor and CS-mount

Order number **LVF-5003C-P2713**

LVF-5005C-S0940 Varifocal lens, 9-40mm, 5MP, CS mount

Varifocal SR megapixel IR corrected lens with 1/2.5" sensor and CS-mount

Order number **LVF-5005C-S0940**

LVF-5005C-S1803 Varifocal lens, 1.8-3mm, 5MP, CS mount

Varifocal SR megapixel IR corrected lens with 1/2.5" sensor and CS-mount

Order number **LVF-5005C-S1803**

LVF-5005C-S4109 Varifocal lens, 4.1-9mm, 5MP, CS mount

Varifocal SR megapixel IR corrected lens with 1/1.8" sensor and CS-mount

Order number **LVF-5005C-S4109**

LVF-5005N-S1250 Varifocal lens, 12-50mm, 5MP, C mount

Varifocal megapixel IR corrected lens with 1/1.8" sensor max and C-mount

Order number **LVF-5005N-S1250**

UPA-1220-60 Power supply, 120VAC 60Hz, 12VDC 1A out

Power supply for camera. 100-240 VAC, 50/60 Hz In; 12 VDC, 1 A Out; regulated.

Input connector: 2-prong, North American standard (non-polarized).

Order number **UPA-1220-60**

UPA-1220-50 Power supply, 220VAC 50Hz, 12VDC 1A out

Power supply for camera. 110-240 VAC, 50/60 Hz In; 12 VDC, 1 A Out; regulated.

Input connector: 2-prong, European Europlug standard (4 mm / 19 mm).

Order number **UPA-1220-50**

TC9210U Camera mount, 6", indoor

A universal 6-inch wall/ceiling grid with off-white finish for 4.5 kg (10 lb) max load, incl. T-Bar ceiling clip and wall/ceiling mount flange.

Order number **TC9210U**

UHO-HBGS-11 Outdoor housing, 24VAC, feed-through

Outdoor housing for (24 VAC / 12 VDC) camera with 24 VAC power supply, blower and feed-through cabling.

Order number **UHO-HBGS-11**

UHO-HBGS-51 Outdoor housing, blower, 230VAC/35W

Outdoor housing for (230 VAC / 12 VDC) camera with 230 VAC power supply, blower and feed-through cabling.

Order number **UHO-HBGS-51**

UHO-HBGS-61 Outdoor housing, blower, 120VAC/35W

Outdoor housing for (120 VAC / 12 VDC) camera. 120 VAC power supply; blower; feed-through cabling

Order number **UHO-HBGS-61**

LTC 9210/01 Column mount, 8", 9KG/20lb load

Feed-through column mount for 20 cm (8 in), 5 kg (11 lb) maximum load; light gray finish; for indoor use.

Order number **LTC 9210/01**

LTC 9215/00 Wall mount with cable feed through, 12"

Wall mount for camera housing, cable feed-through, 30 cm (12 in); for outdoor use.

Order number **LTC 9215/00**

LTC 9215/00S Wall mount for UHI/UHO

Wall mount for camera housing, cable feed-through, 18 cm (7 in); for indoor use.

Order number **LTC 9215/00S**

LTC 9219/01 Feed through J mount

J-mount for camera housing, 40 cm (15 in); for indoor use.

Order number **LTC 9219/01**

LTC 9213/01 Pole mount adapter for LTC9210,9212,9215

Flexible pole mount adapter for camera mounts (use together with the appropriate wall mount bracket). Max. 9 kg (20 lb); 3 to 15 inch diameter pole; stainless steel straps

Order number **LTC 9213/01**

NBN-MCSMB-03M Cable, SMB to BNC, camera-cable, 0.3m

0.3 m (1 ft) analog cable, SMB (female) to BNC (female) to connect camera to coaxial cable

Order number **NBN-MCSMB-03M**

NBN-MCSMB-30M Cable, SMB to BNC, camera-monitor/DVR

3 m (9 ft) analog cable, SMB (female) to BNC (male) to connect camera to monitor or DVR

Order number **NBN-MCSMB-30M**

VJT-XTCXF VIDEOJET XF TRANSCODER

High-performance video transcoder. H.264; CF card slot; ROI; max resolution 1080p; 2 channels

Order number **VJT-XTCXF**

NPD-5001-POE Midspan, 15W, single port, AC in

Power-over-Ethernet midspan injector for use with PoE enabled cameras; 15.4 W, 1-port

Weight: 200 g (0.44 lb)

Order number **NPD-5001-POE**

NPD-5004-POE Midspan, 4 port x 15W, AC in

Power-over-Ethernet midspan injector for use with PoE enabled cameras; 15.4 W, 4-ports

Weight: 620 g (1.4 lb)

Order number **NPD-5004-POE**

UHO-POE-10 Outdoor housing, POE + power supply

Outdoor camera housing with PoE+ power supply.

Order number **UHO-POE-10**

Represented by:

Europe, Middle East, Africa:
Bosch Security Systems B.V.
P.O. Box 80002
5600 JB Eindhoven, The Netherlands
Phone: + 31 40 2577 284
emea.securitysystems@bosch.com
emea.boschsecurity.com

Germany:
Bosch Sicherheitssysteme GmbH
Robert-Bosch-Ring 5
85630 Grasbrunn
Germany
www.boschsecurity.com

North America:
Bosch Security Systems, LLC
130 Perinton Parkway
Fairport, New York, 14450, USA
Phone: +1 800 289 0096
Fax: +1 585 223 9180
onlinehelp@us.bosch.com
www.boschsecurity.us

Asia-Pacific:
Robert Bosch (SEA) Pte Ltd, Security Systems
11 Bishan Street 21
Singapore 573943
Phone: +65 6571 2808
Fax: +65 6571 2699
apr.securitysystems@bosch.com
www.boschsecurity.asia